

# N-Channel Enhancement Mode MOSFET

## 1. Product Information

### 1.1 Features

- Surface-mounted package
- Super Trench
- Tj max 175°C
- Advanced trench cell design
- MSL1

### 1.2 Applications

- E- Tool appliances
- BMS appliances
- High power inverter system
- Inverter appliances

### 1.3 Quick reference

- BV ≥ 85 V
- P<sub>tot</sub> ≤ 250 W
- I<sub>D</sub> ≤ 220 A
- R<sub>DS(ON)</sub> ≤ 2.8mΩ @ V<sub>GS</sub> = 10 V

## 2. Pin Description

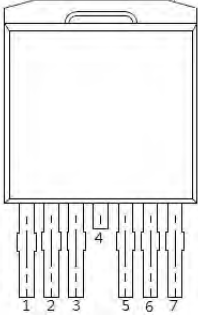
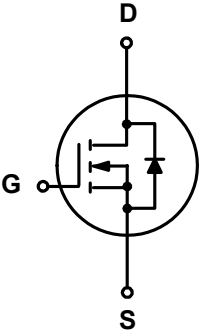
Pin	Description	Simplified Outline	Symbol
1	Gate(G)	 <p>Top View TO-263-7L(D2PAK)</p>	
2,3	Source (S)		
4	Drain(D)		
5,6,7	Source (S)		

### 3. Limiting Values

Symbol	Parameter	Conditions	Min	Max	Unit
V <sub>DS</sub>	Drain-Source Voltage	T <sub>C</sub> = 25 °C	85	-	V
V <sub>GS</sub>	Gate-Source Voltage	T <sub>C</sub> = 25 °C	-	±20	V
I <sub>D</sub> <sup>***</sup>	Drain Current ( DC )	T <sub>C</sub> = 25 °C, V <sub>GS</sub> = 10 V	-	220	A
		T <sub>C</sub> = 100 °C, V <sub>GS</sub> = 10 V	-	156	A
I <sub>DM</sub> <sup>*,***</sup>	Drain Current ( Pulsed )	T <sub>C</sub> = 25 °C, V <sub>GS</sub> = 10 V	-	800	A
P <sub>tot</sub>	Drain power dissipation	T <sub>C</sub> = 25 °C	-	250	W
T <sub>stg</sub>	Storage Temperature		-55	175	°C
T <sub>J</sub>	Junction Temperature		-	175	°C
I <sub>S</sub>	Continuous-Source Current	T <sub>C</sub> = 25 °C	-	220	A
E <sub>AS</sub>	Single Pulsed Avalanche Energy	V <sub>DD</sub> =100V , L=0.1mH	-	805	mJ
R <sub>θJA</sub> <sup>**</sup>	Thermal Resistance- Junction to Ambient		-	32	°C/W
R <sub>θJC</sub> <sup>**</sup>	Thermal Resistance- Junction to Case		-	0.45	

Notes :

- \* Pulse width ≤ 300 μs, duty cycle ≤ 2 %
- \*\* Surface Mounted on minimum footprint pad area.
- \*\*\* Limited by bonding wire

### 4. Marking Information

Product Name	Marking
UP02N08D7	<div style="border: 1px solid black; padding: 5px; display: inline-block;"> <b>N02N08D7</b>  <b>AYWW01</b>  <b>XXXXXX</b> </div>

### 5. Ordering Code

Product Name	Package	Reel Size	Tape width	Quantity	Note
UP02N08D7	TO263-7(D2-PAK)			800	

Note: UOE defines “ Green ” as lead-free ( RoHS compliant ) and halogen free ( Br or Cl does not exceed 900 ppm by weight in homogeneous material and total of Br and Cl does not exceed 1500 ppm by weight; Follow IEC 61249-2-21 and IPC / JEDEC J-STD-020C )

**6. Electrical Characteristics** (  $T_A=25^\circ$  Unless Otherwise Noted )

Symbol	Parameter	Conditions	Min	Typ	Max	Unit
<b>Static Characteristics</b>						
$BV_{DSS}$	Drain-Source Breakdown Voltage	$V_{GS} = 0\text{ V}, I_{DS} = 250\ \mu\text{A}$	85	95	-	V
$V_{GS(th)}$	Gate Threshold Voltage	$V_{DS} = V_{GS}, I_{DS} = 250\ \mu\text{A}$	2	-	4	V
$I_{DSS}$	Drain Leakage Current	$V_{DS} = 85\text{V}, V_{GS} = 0\text{ V}$	-	-	1	$\mu\text{A}$
		$T_J = 85^\circ\text{C}$	-	-	30	$\mu\text{A}$
$I_{GSS}$	Gate Leakage Current	$V_{GS} = 0\text{ V}, V_{GS} = \pm 20\text{ V}$	-	-	$\pm 100$	nA
$R_{DS(on)}^a$	On-State Resistance	$V_{GS} = 10\text{ V}, I_{DS} = 30\text{ A}$	-	2.4	2.8	m $\Omega$
<b>Diode Characteristics</b>						
$V_{SD}^a$	Diode Forward Voltage	$I_{SD} = 30\text{ A}, V_{GS} = 0\text{ V}$	-	-	1.2	V
$t_{rr}$	Reverse Recovery Time	$I_{DS} = 30\text{ A}, V_{GS} = 0\text{ V}$ $di_{SD}/dt = 100\text{ A}/\mu\text{s}$	-	78	-	nS
$Q_{rr}$	Reverse Recovery Charge		-	110	-	nC
<b>Dynamic Characteristics<sup>b</sup></b>						
$C_{iss}$	Input Capacitance	$V_{GS} = 0\text{ V}, V_{DS} = 40\text{ V}$ Frequency = 1 MHz	-	6234	-	pF
$C_{oss}$	Output Capacitance		-	1180	-	
$C_{riss}$	Reverse Transfer Capacitance		-	97	-	
$t_{d(on)}$	Turn-on Delay Time	$V_{DS} = 40\text{ V}, V_{GEN} = 10\text{ V},$ $R_G = 4.5\ \Omega, R_L = 1.3\ \Omega,$ $I_{DS} = 30\text{ A}$	-	41	-	nS
$t_r$	Turn-on Rise Time		-	68	-	
$t_{d(off)}$	Turn-off Delay Time		-	76	-	
$t_f$	Turn-off Fall Time		-	44	-	
<b>Gate Charge Characteristics<sup>b</sup></b>						
$Q_g$	Total Gate Charge	$V_{DS} = 40\text{ V}, V_{GS} = 10\text{ V},$ $I_{DS} = 30\text{ A}$	-	124	-	nC
$Q_{gs}$	Gate-Source Charge		-	31.2	-	
$Q_{gd}$	Gate-Drain Charge		-	39.2	-	

Notes :

 a : Pulse test ; pulse width  $\leq 300\ \mu\text{s}$ , duty cycle  $\leq 2\%$ 

b : Guaranteed by design, not subject to production testing

### 7. Typical Characteristics

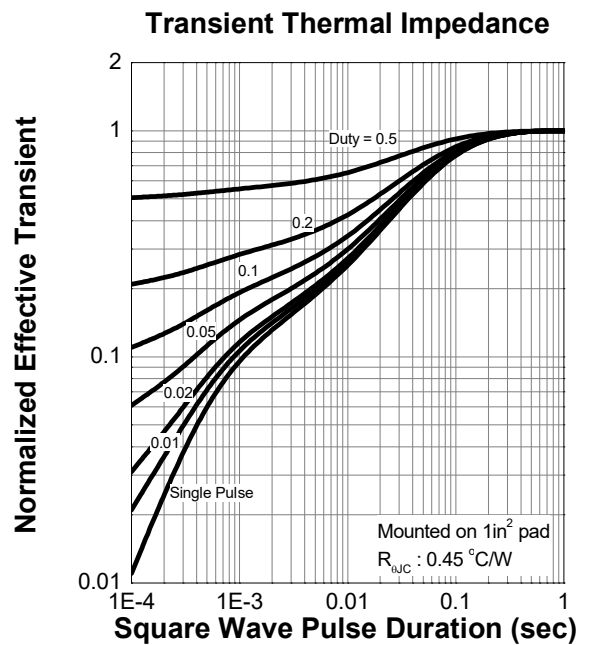
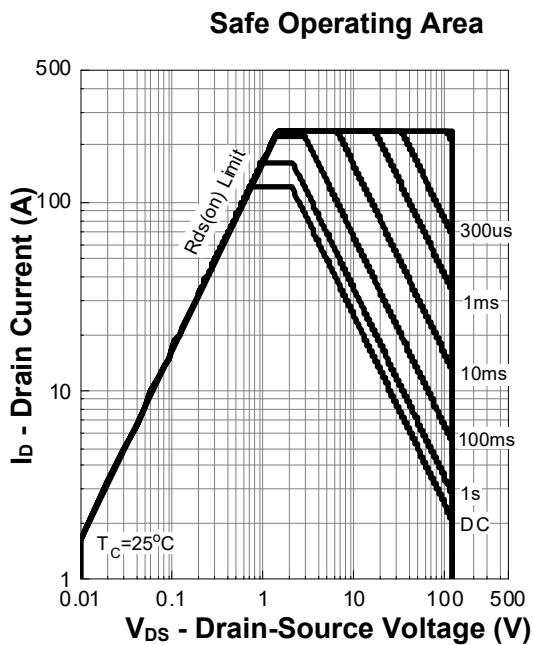
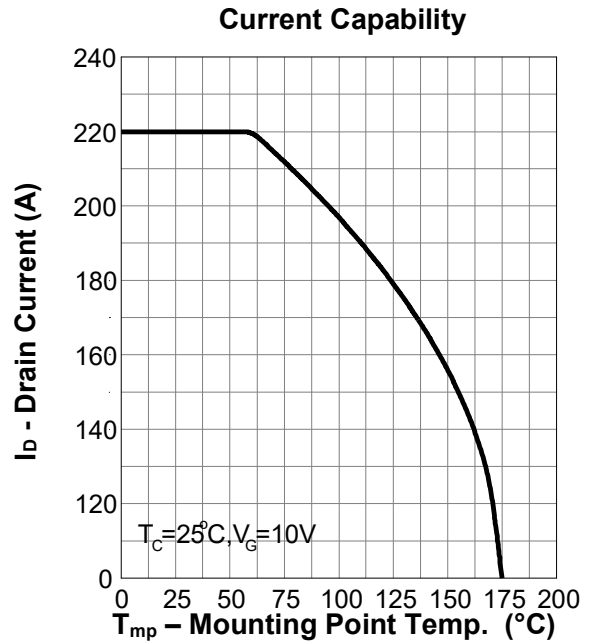
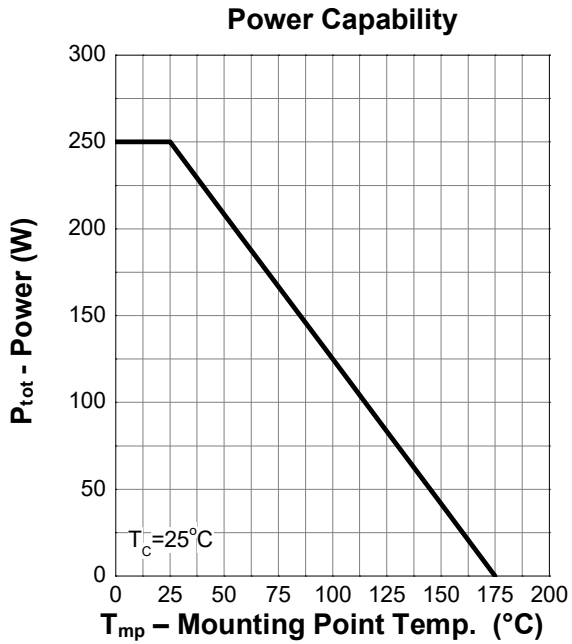

7. Typical Characteristics (cont.)

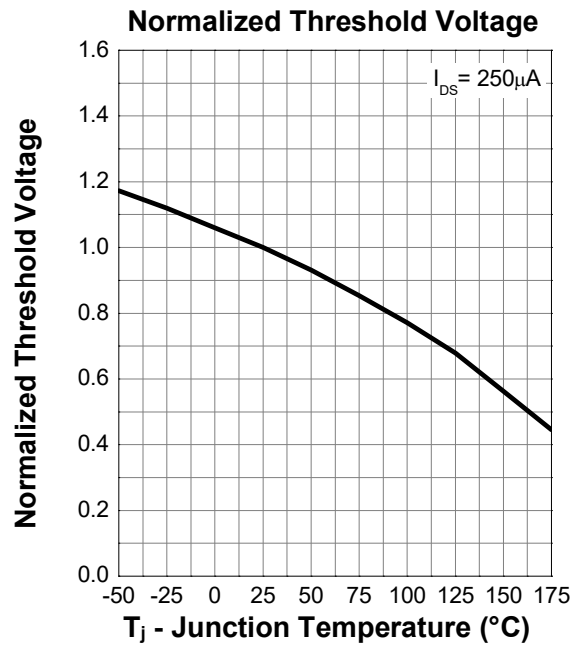
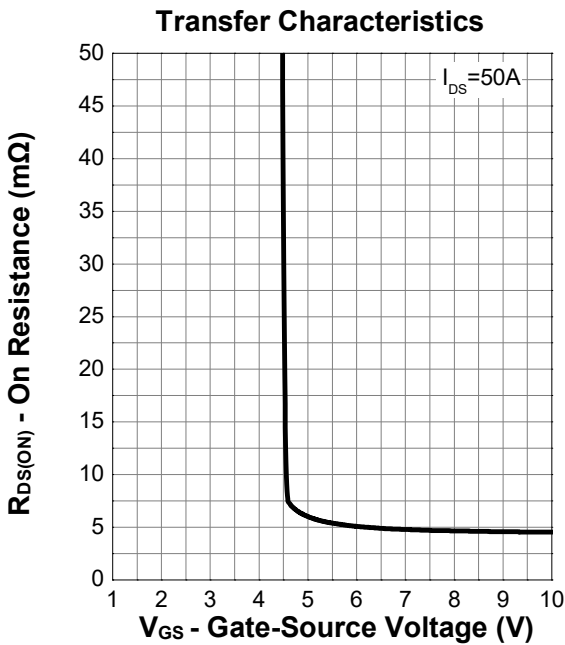
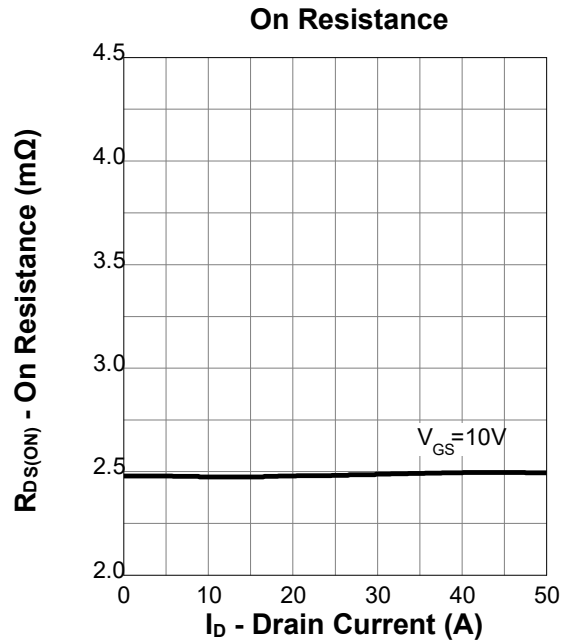
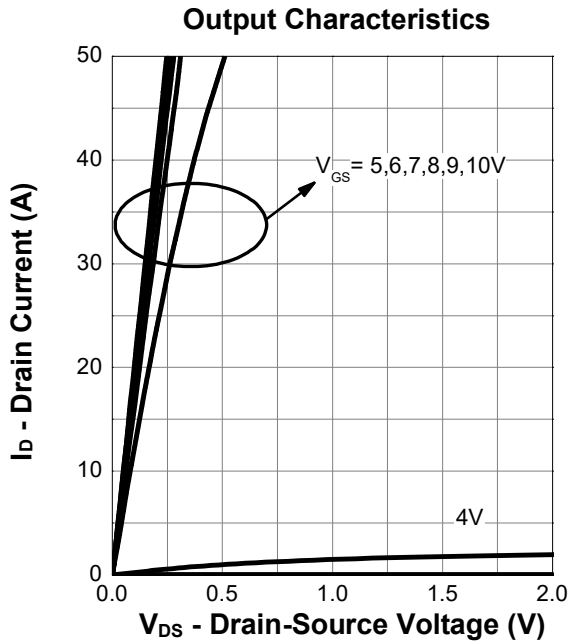

7. Typical Characteristics (cont.)

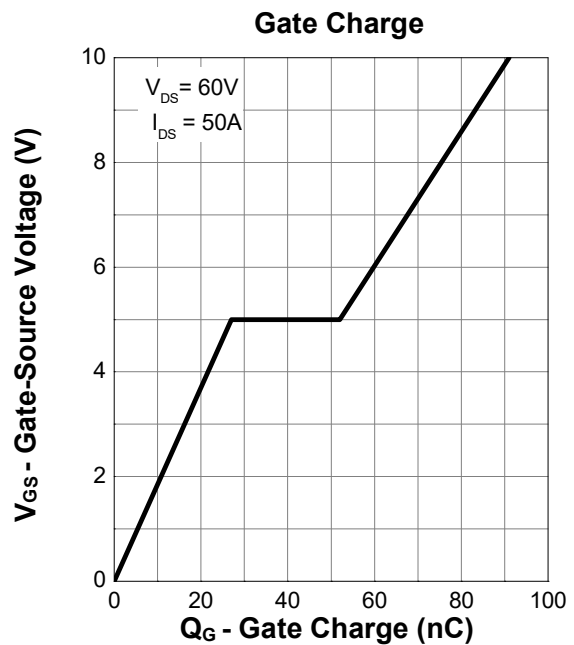
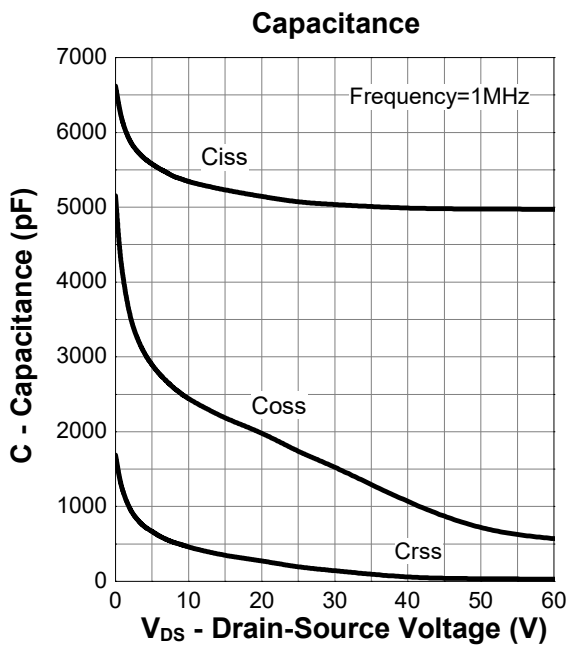
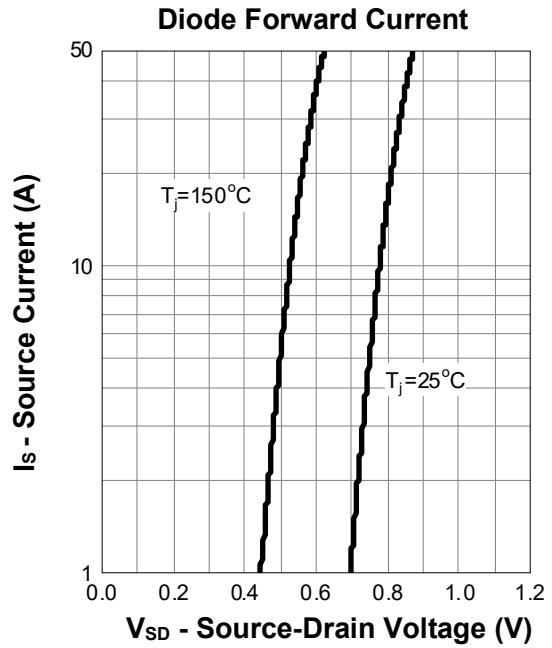
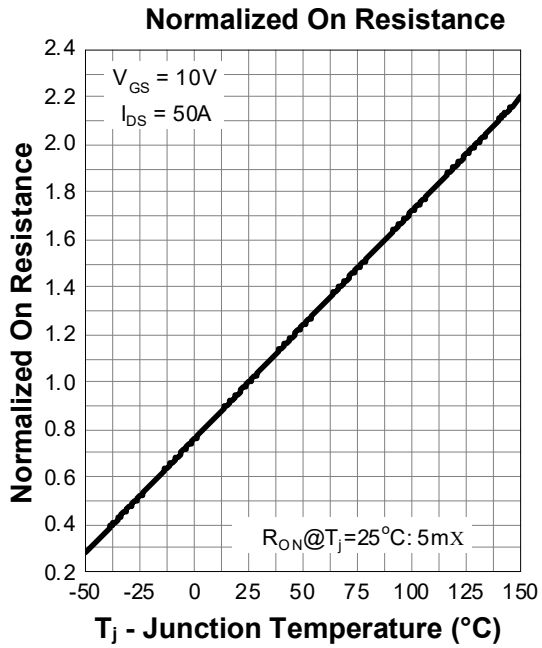

## 8. Package Dimensions

### TO-263-7L Package

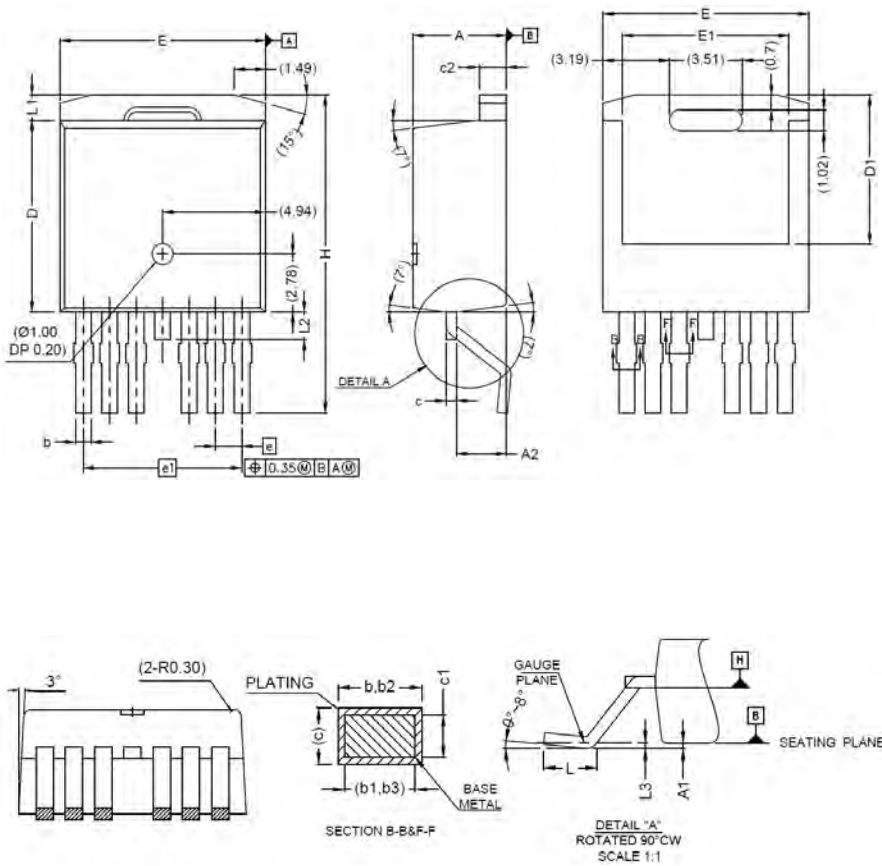

Symbol	Dimensions In Millimeters	
	MIN.	MAX.
A	4.30	4.70
A1	-	0.25
A2	2.20	2.60
b	0.65	0.85
b1	0.65	0.80
b2	0.80	1.00
b3	0.80	0.95
c	0.45	0.60
c1	0.45	0.55
c2	1.25	1.40
D	9.00	9.40
D1	6.86	7.42
E	9.68	10.08
E1	7.70	8.30
e	1.27 BSC	
e1	7.62 BSC	
L	1.78	2.79
L1	-	1.60
L2	-	1.78
L3	0.25BSD	
H	14.61	15.88