

## N-Channel Enhancement Mode MOSFET

### 1. Product Information

#### 1.1 Features

- Surface-mounted package
- Advanced trench cell design

#### 1.2 Applications

- LCD TV appliances
- High power inverter system
- LCDM appliances

#### 1.3 Quick reference

- $BV \geq 80\text{ V}$
- $R_{DS(ON)} \leq 1.38\text{ m}\Omega @ V_{GS} = 10\text{ V}$
- $P_{tot} \leq 150\text{ W}$
- $R_{DS(ON)} \leq 2.15\text{ m}\Omega @ V_{GS} = 6\text{ V}$
- $I_D \leq 213\text{ A}$

### 2. Pin Description

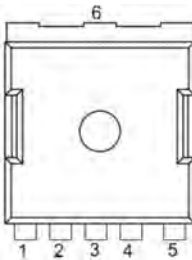
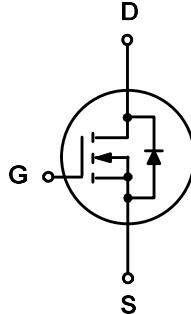
Pin	Description	Simplified Outline	Symbol
1,2,3,4	Source(S)	 <p style="text-align: center;">Top View STOLL</p>	
5	Gate(G)		
6	Drain(D)		

### 3. Limiting Values

Symbol	Parameter	Conditions	Min	Max	Unit
V <sub>DS</sub>	Drain-Source Voltage	T <sub>C</sub> = 25 °C	-	80	V
V <sub>GS</sub>	Gate-Source Voltage	T <sub>C</sub> = 25 °C	-	± 20	V
I <sub>D</sub> *	Drain Current ( DC )	T <sub>C</sub> = 25 °C, V <sub>GS</sub> = 10 V	-	213	A
		T <sub>C</sub> = 100 °C, V <sub>GS</sub> = 10 V	-	150	A
I <sub>DM</sub> *,**	Drain Current ( Pulsed )	T <sub>C</sub> = 25 °C, V <sub>GS</sub> = 10 V	-	852	A
P <sub>tot</sub>	Drain power dissipation	T <sub>C</sub> = 25 °C	-	150	W
T <sub>stg</sub>	Storage Temperature		- 55	175	°C
T <sub>J</sub>	Junction Temperature		-	175	°C
I <sub>S</sub>	Continuous-Source Current	T <sub>C</sub> = 25 °C	-	213	A
E <sub>AS</sub> *	Single Pulsed Avalanche Energy	V <sub>DD</sub> = 50 V , L = 1.0 mH	-	1512	mJ
R <sub>θJA</sub> *	Thermal Resistance- Junction to Ambient		-	45	°C/W
R <sub>θJC</sub>	Thermal Resistance- Junction to Case		-	1	

Notes :

- \* Surface Mounted on 1 in<sup>2</sup> pad area, t ≤ 10 sec
- \*\* Pulse width ≤ 300 μs, duty cycle ≤ 2 %
- \*\*\* Limited by bonding wire

### 4. Marking Information

Product Name	Marking
US013N08ST	<div style="display: inline-block; background-color: black; color: white; padding: 2px;">013N08</div> <div style="display: inline-block; background-color: black; color: white; padding: 2px;">YWWXXX</div> <div style="display: inline-block; vertical-align: middle;">YWWXXX: Date Code</div>

### 5. Ordering Code

Product Name	Package	Reel Size	Tape width	Quantity	Note
US013N08ST	sTOLL			2000	

## 6. Electrical Characteristics (T<sub>A</sub> = 25 °C Unless Otherwise Noted)

Symbol	Parameter	Conditions	Min	Typ	Max	Unit
<b>Static Characteristics</b>						
BV <sub>DSS</sub>	Drain-Source Breakdown Voltage	V <sub>GS</sub> = 0 V, I <sub>DS</sub> = 250 μA	80	-	-	V
V <sub>GS(th)</sub>	Gate Threshold Voltage	V <sub>DS</sub> = V <sub>GS</sub> , I <sub>DS</sub> = 250 μA	2	-	4	V
I <sub>DSS</sub>	Drain Leakage Current	V <sub>DS</sub> = 64 V, V <sub>GS</sub> = 0 V	-	-	1	μA
I <sub>GSS</sub>	Gate Leakage Current	V <sub>GS</sub> = 0 V, V <sub>GS</sub> = ± 20 V	-	-	± 100	nA
R <sub>DS(ON)</sub> <sup>a</sup>	On-State Resistance	V <sub>GS</sub> = 10 V, I <sub>DS</sub> = 50 A	-	1.2	1.38	mΩ
		V <sub>GS</sub> = 6 V, I <sub>DS</sub> = 30 A	-	1.8	2.15	
<b>Diode Characteristics</b>						
V <sub>SD</sub> <sup>a</sup>	Diode Forward Voltage	I <sub>SD</sub> = 50 A, V <sub>GS</sub> = 0 V	-	-	1.3	V
t <sub>rr</sub>	Reverse Recovery Time	I <sub>DS</sub> = 50 A, V <sub>GS</sub> = 0 V di <sub>SD</sub> /dt = 100 A/μs	-	96	-	nS
Q <sub>rr</sub>	Reverse Recovery Charge		-	134	-	nC
<b>Dynamic Characteristics<sup>b</sup></b>						
C <sub>iss</sub>	Input Capacitance	V <sub>GS</sub> = 0 V, V <sub>DS</sub> = 40 V Frequency = 1 MHz	-	8689	-	pF
C <sub>oss</sub>	Output Capacitance		-	1468	-	
C <sub>rss</sub>	Reverse Transfer Capacitance		-	46	-	
t <sub>d(on)</sub>	Turn-on Delay Time	V <sub>DS</sub> = 40 V, V <sub>GEN</sub> = 10 V, R <sub>G</sub> = 3.9 Ω, R <sub>L</sub> = 0.8 Ω, I <sub>DS</sub> = 50 A	-	31	-	nS
t <sub>r</sub>	Turn-on Rise Time		-	81	-	
t <sub>d(off)</sub>	Turn-off Delay Time		-	117	-	
t <sub>f</sub>	Turn-off Fall Time		-	71	-	
<b>Gate Charge Characteristics<sup>b</sup></b>						
Q <sub>g</sub>	Total Gate Charge	V <sub>DS</sub> = 40 V, V <sub>GS</sub> = 10 V, I <sub>DS</sub> = 50 A	-	174	-	nC
Q <sub>gs</sub>	Gate-Source Charge		-	44	-	
Q <sub>gd</sub>	Gate-Drain Charge		-	52	-	

Notes :

a : Pulse test ; pulse width ≤ 300 μs, duty cycle ≤ 2%

b : Guaranteed by design, not subject to production testing

### 7. Typical Characteristics

Power Capability

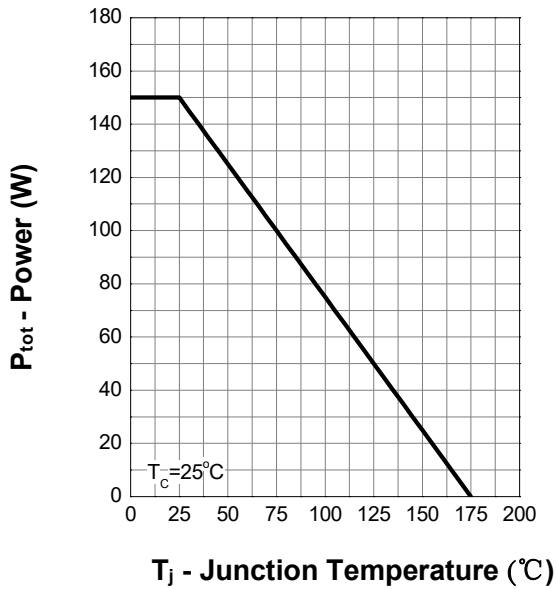

Current Capability

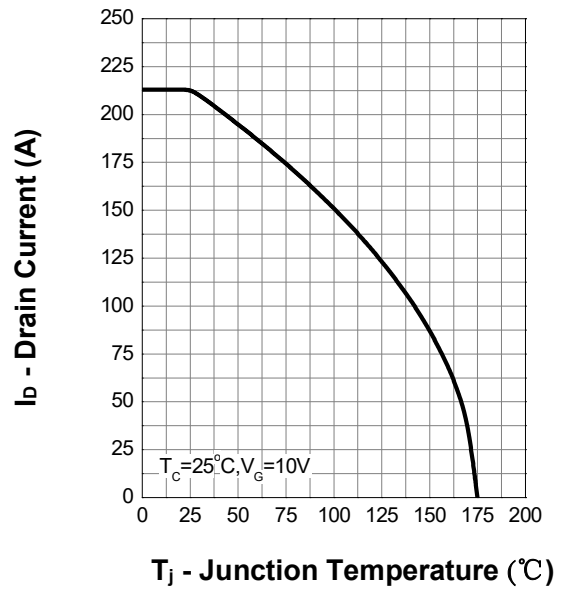

Safe Operation Area

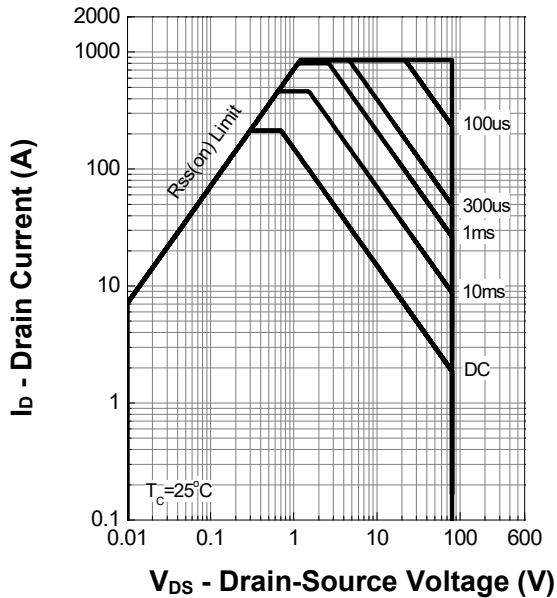

Thermal Transient Impedance

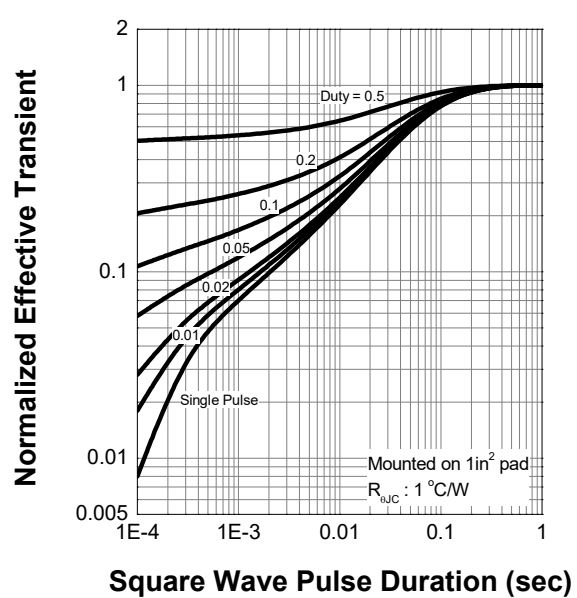

### 7. Typical Characteristics (cont.)

Output Characteristics

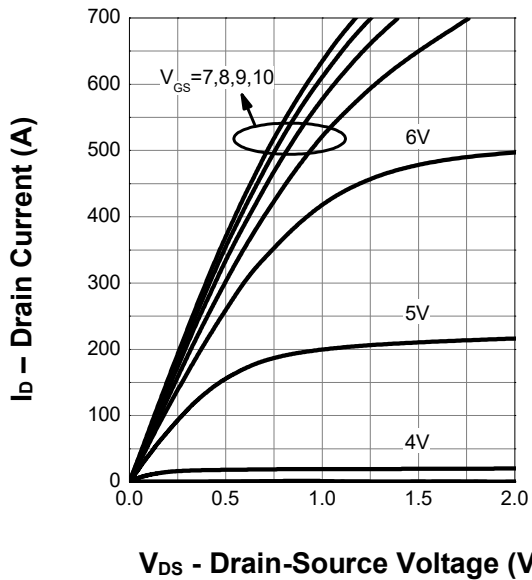

Drain-Source On Resistance

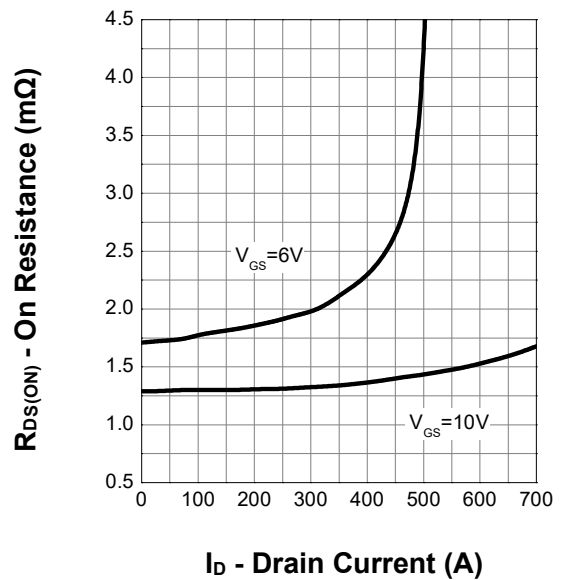

Transfer Characteristics

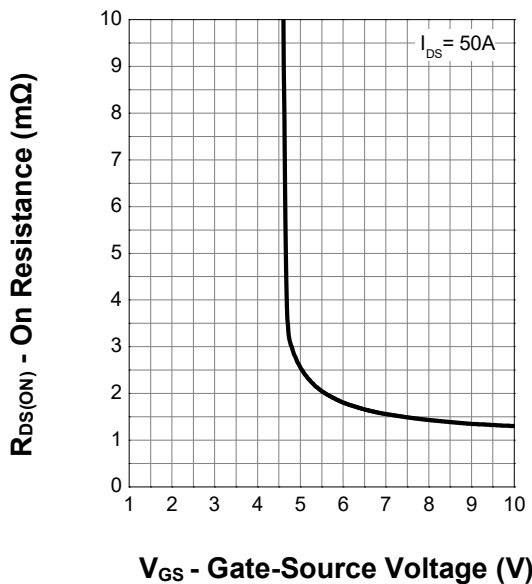

Gate Threshold Voltage

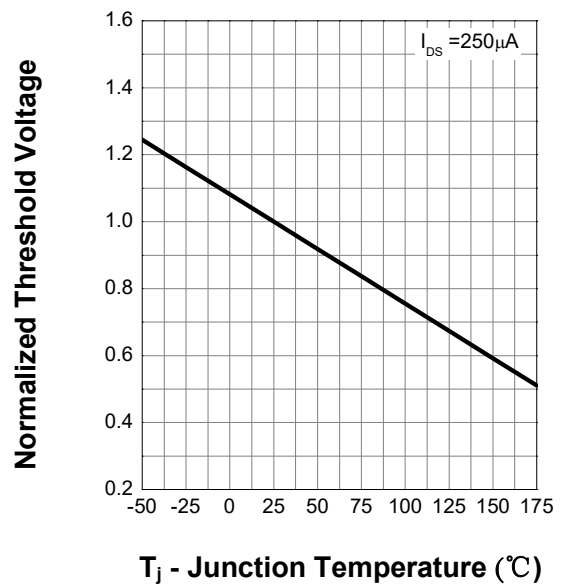

7. Typical Characteristics (cont.)

Drain-Source On Resistance

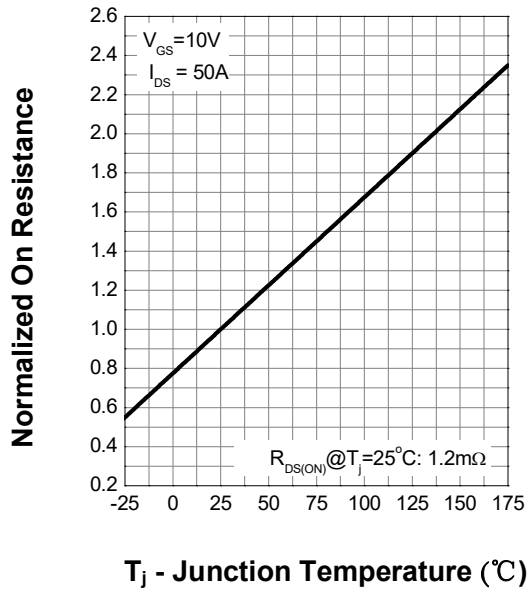

Body Diode Characteristics

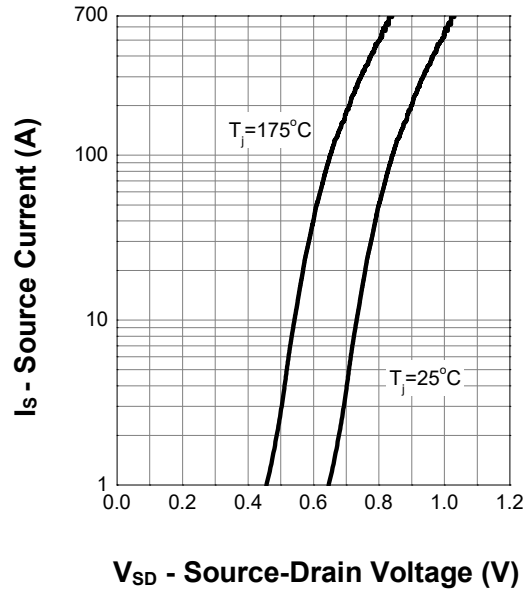

Capacitance

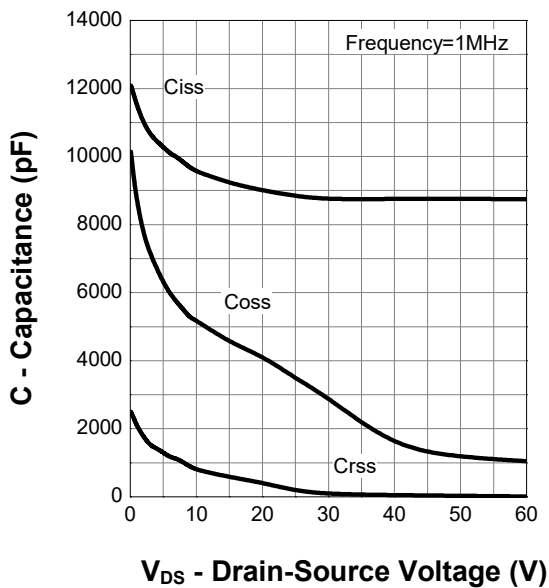

Gate Charge

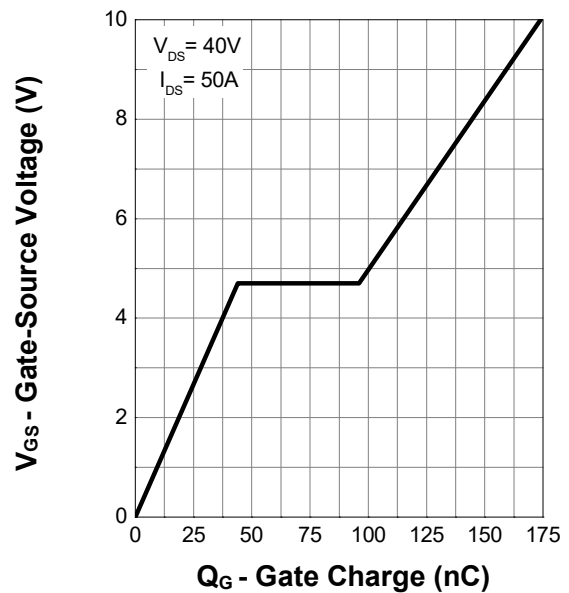

## 8. Package Dimensions

sTOLL Package

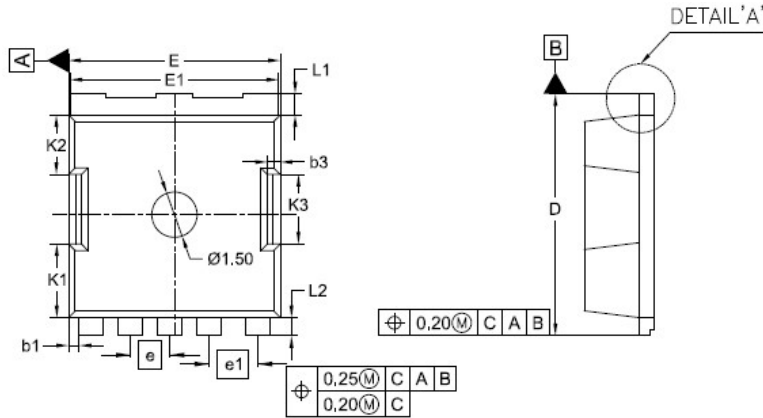

TOP VIEW

SIDE VIEW

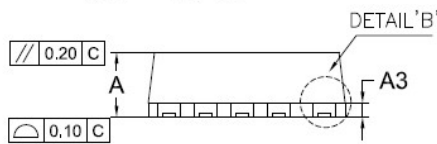

SIDE VIEW

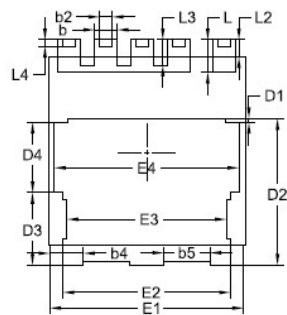

BOTTOM VIEW

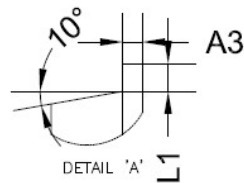

DETAIL 'A'

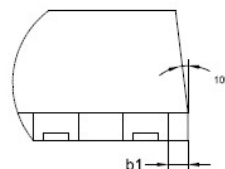

DETAIL 'B'

SYMBOLS	DIMENSION IN MM		
	MIN	NOM	MAX
A	2.300	2.200	2.400
A3	0.490	0.500	0.508
D	7.900	8.000	8.100
E	6.900	7.000	7.100
e	1.30 BSC		
e1	1.60 BSC		
D1	0.130 ref		
D2	5.100	5.200	5.300
D3	2.470	2.570	2.670
D4	2.400	2.500	2.600
b	0.750	0.800	0.850
b1	0.350 ref		
b2	0.350	0.450	0.550
b3	0.425 ref		
b4	1.100	1.200	1.300
b5	1.550	1.650	1.750
L	1.050	1.150	1.250
L1	0.600	0.700	0.800
L2	0.500	0.600	0.700
L3	0.800	0.900	1.000
L4	0.135	0.235	0.335
E1	6.800	6.900	7.000
E2	5.860	5.960	6.060
E3	5.560	5.660	5.760
E4	6.460	6.560	6.660
K1	2.430 ref		
K2	1.970 ref		