

N-Channel Enhancement Mode MOSFET

1. Product Information

1.1 Features

- Surface-mounted package
- Low Thermal Resistance

1.2 Applications

- Motor drivers
- DC - DC Converter

1.3 Quick reference

- $BV \geq 40\text{ V}$
- $R_{DS(ON)} \leq 0.68\text{ m}\Omega @ V_{GS} = 10\text{ V}$
- $P_{tot} \leq 250\text{ W}$
- $R_{DS(ON)} \leq 1.39\text{ m}\Omega @ V_{GS} = 4.5\text{ V}$
- $I_D \leq 300\text{ A}$

2. Pin Description

Pin	Description	Simplified Outline	Symbol
1,2,3	Source	<p style="text-align: center;">Top View LFPAK5*6</p>	
4	Gate		
Tab	Drain		

3. Limiting Values

Symbol	Parameter	Conditions	Min	Max	Unit
V _{DS}	Drain-Source Voltage	T _C = 25 °C	-	40	V
V _{GS}	Gate-Source Voltage	T _C = 25 °C	-	± 20	V
I _D ^{*,***}	Drain Current	T _C = 25 °C, V _{GS} = 10 V	-	300	A
		T _C = 100 °C, V _{GS} = 10 V	-	281	A
I _{DM} ^{*,**}	Pulsed Source Current	T _C = 25 °C, V _{GS} = 10 V	-	1200	A
P _{tot} [*]	Total Power Dissipation	T _C = 25 °C	-	250	W
T _{stg}	Storage Temperature		- 55	175	°C
T _J	Junction Temperature		-	175	°C
I _S	Diode Forward Current	T _C = 25 °C	-	300	A
E _{AS} [*]	Single Pulsed Avalanche Energy	V _{DD} = 50 V , L = 1.0 mH	-	800	mJ
R _{θJA} [*]	Thermal Resistance- Junction to Ambient		-	60	°C / W
R _{θJC} [*]	Thermal Resistance- Junction to Case		-	0.6	

Notes :

- * Surface Mounted on 1 in² pad area, t ≤ 10 sec
- ** Pulse width ≤ 300 μs, duty cycle ≤ 2 %
- *** Limited by bonding wire

4. Marking Information

Product Name	Marking
UK009N04LFL	<div style="display: flex; align-items: center;"> <div style="background-color: black; color: white; padding: 5px; margin-right: 10px;"> 009N04L YWW01 AAAAAA </div> <div> YWW01: Date Code </div> </div>

5. Ordering Code

Product Name	Package	Reel Size	Tape width	Quantity	Note
UK009N04LFL	LFLPAK5*6			5000	

6. Electrical Characteristics (T_A = 25 °C Unless Otherwise Noted)

Symbol	Parameter	Conditions	Min	Typ	Max	Unit
Static Characteristics						
BV _{DSS}	Drain-Source Breakdown Voltage	V _{GS} = 0 V, I _{DS} = 250 μA	40	-	-	V
V _{GS(th)}	Gate Threshold Voltage	V _{DS} = V _{GS} , I _{DS} = 250 μA	1	-	2.5	V
I _{DSS}	Drain Leakage Current	V _{DS} = 32 V, V _{GS} = 0 V	-	-	1	μA
I _{GSS}	Gate Leakage Current	V _{GS} = 0 V, V _{GS} = ± 20 V	-	-	±100	nA
R _{DS(on)} ^a	On-State Resistance	V _{GS} = 10 V, I _{DS} = 30 A	-	0.57	0.68	mΩ
		V _{GS} = 4.5 V, I _{DS} = 20 A	-	1.07	1.39	
Diode Characteristics						
V _{SD} ^a	Diode Forward Voltage	I _{SD} = 30 A, V _{GS} = 0 V	-	-	1.3	V
t _{rr}	Reverse Recovery Time	I _{DS} = 30 A, V _{GS} = 0 V	-	71	-	nS
Q _{rr}	Reverse Recovery Charge	di _{SD} /dt = 100 A/μs	-	77	-	nC
Dynamic Characteristics^b						
C _{iss}	Input Capacitance	V _{GS} = 0 V, V _{DS} = 20 V Frequency = 1 MHz	-	5733	-	pF
C _{oss}	Output Capacitance		-	2609	-	
C _{rss}	Reverse Transfer Capacitance		-	154	-	
t _{d(on)}	Turn-on Delay Time	V _{DS} = 20 V, V _{GEN} = 10 V, R _G = 3.9 Ω, R _L = 0.66 Ω, I _{DS} = 30 A	-	18	-	nS
t _r	Turn-on Rise Time		-	73	-	
t _{d(off)}	Turn-off Delay Time		-	102	-	
t _f	Turn-off Fall Time		-	70	-	
Gate Charge Characteristics^b						
Q _g	Total Gate Charge	V _{DS} = 20 V, V _{GS} = 10 V, I _{DS} = 30 A	-	111	-	nC
Q _{gs}	Gate-Source Charge		-	21	-	
Q _{gd}	Gate-Drain Charge		-	27	-	

Notes :

a : Pulse test ; pulse width ≤ 300 μs, duty cycle ≤ 2%

b : Guaranteed by design, not subject to production testing

7. Typical Characteristics

Power Capability

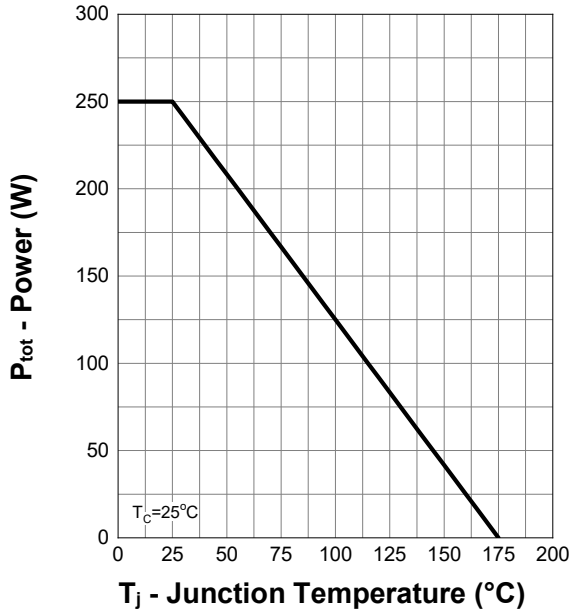

Current Capability

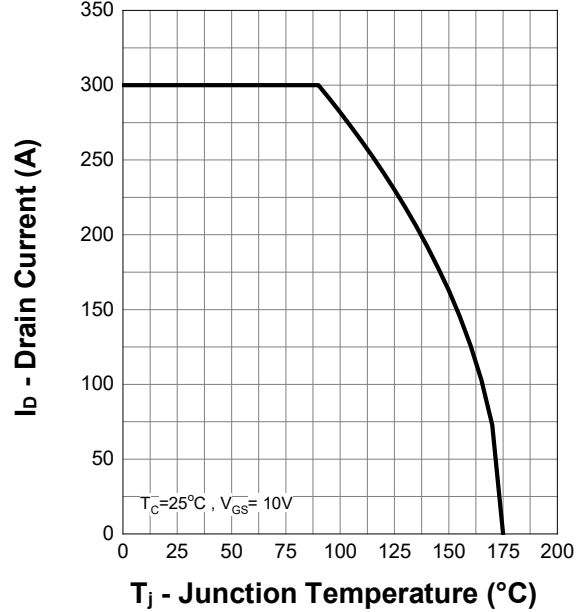

Safe Operating Area

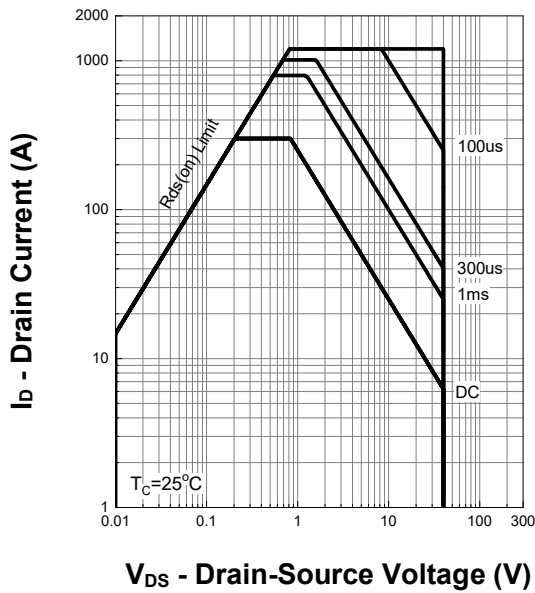

Transient Thermal Impedance

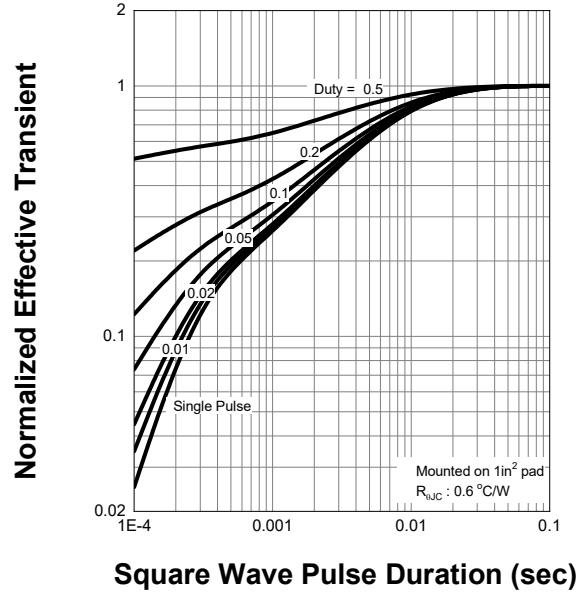

7. Typical Characteristics (cont.)

Output Characteristics

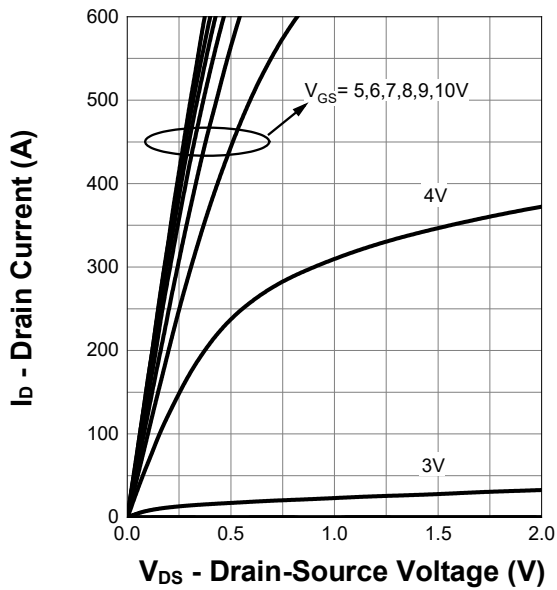

On Resistance

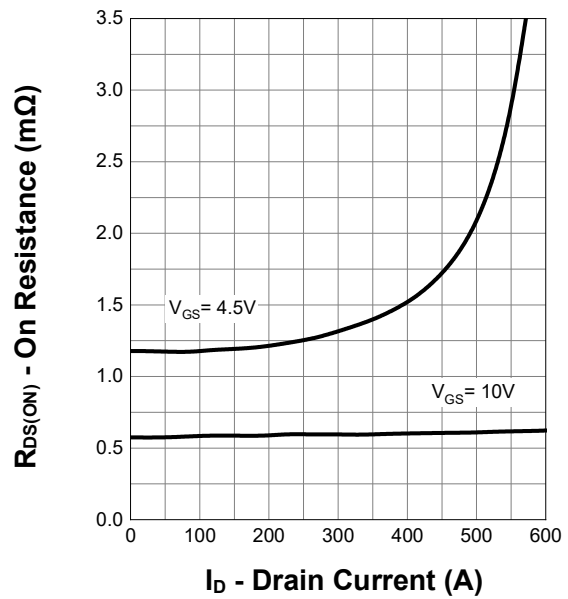

Transfer Characteristics

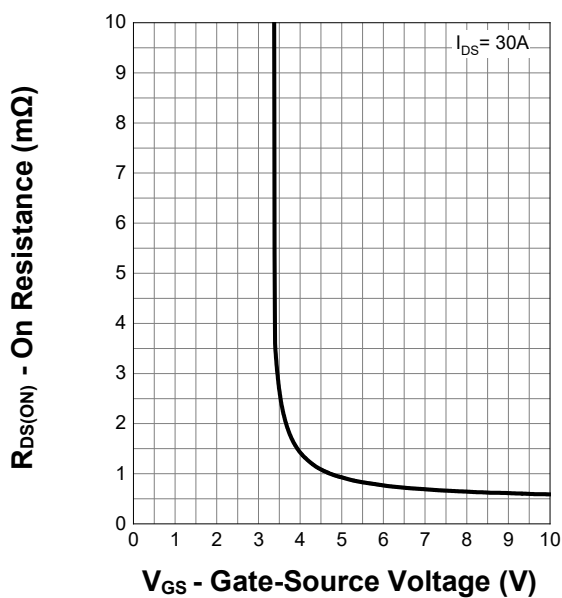

Normalized Threshold Voltage

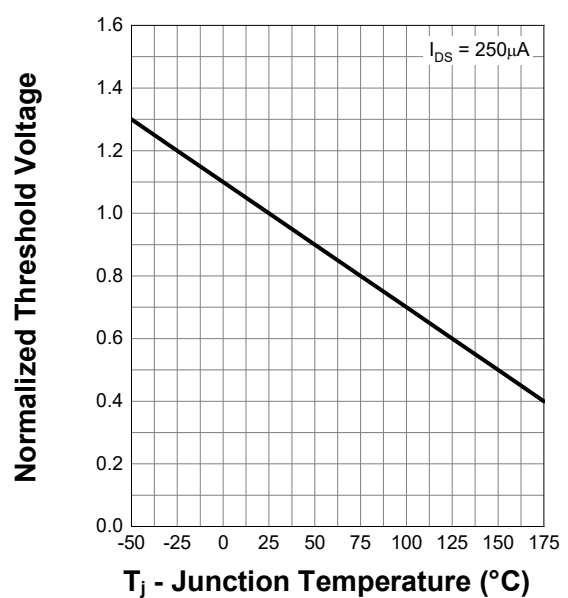

7. Typical Characteristics (cont.)

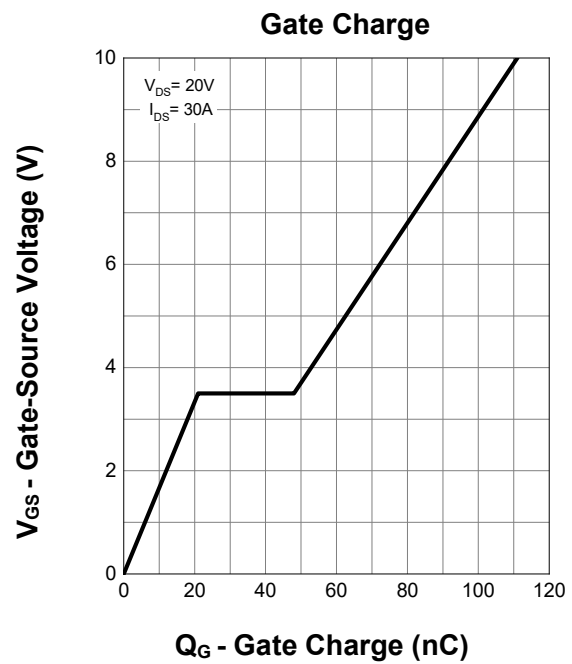
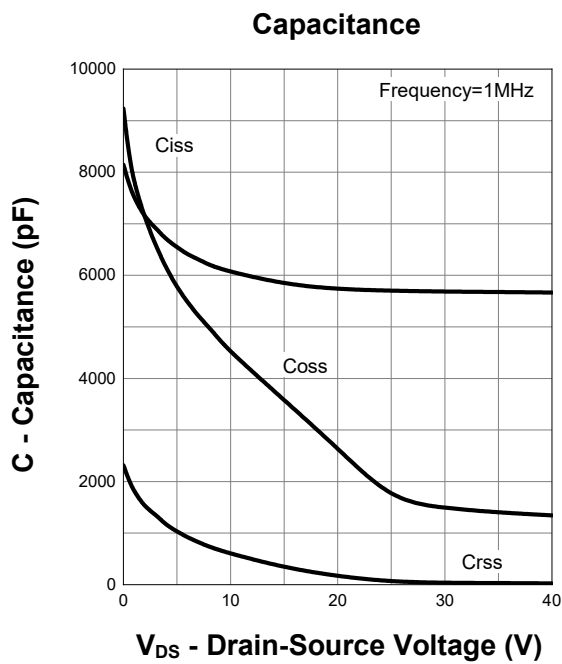
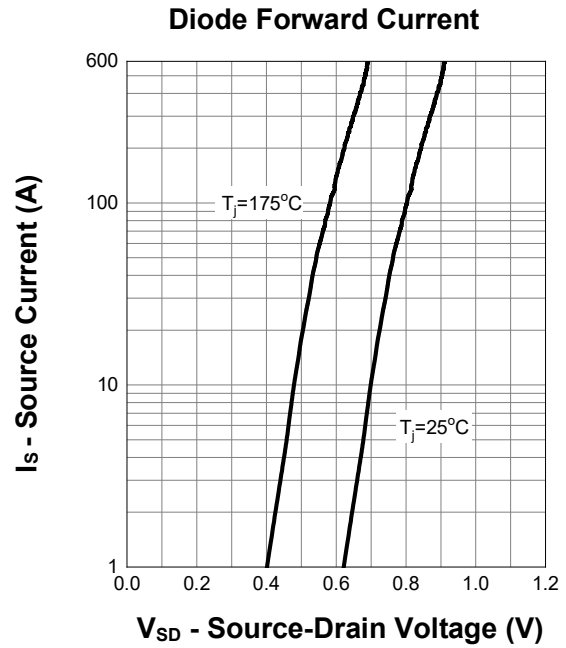
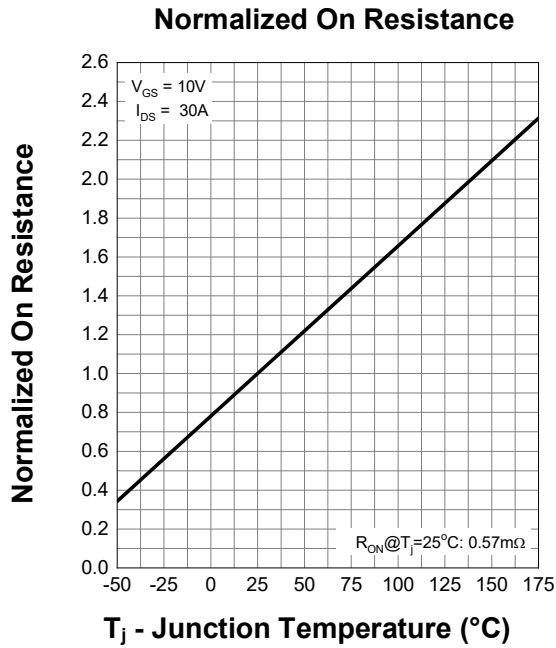

8. Package Dimensions LFLPAK5*6 Package

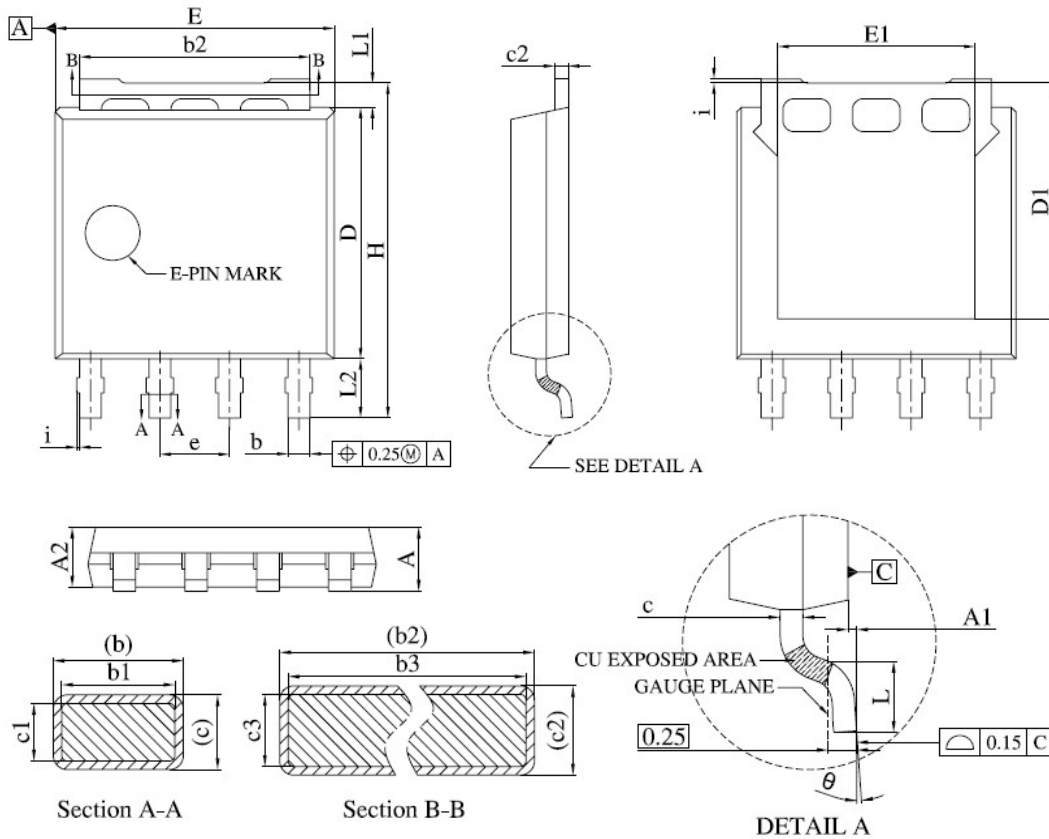

Symbol	Dimensions In Millimeters	
	MIN.	MAX.
A	1.00	1.30
A1	0.00	0.15
A2	0.98	1.12
b	0.35	0.50
b1	0.32	0.46
b2	4.02	4.41
b3	4.00	4.37
c	0.19	0.25
c1	0.17	0.23
c2	0.24	0.30
c3	0.22	0.28
D	4.45	4.70
D1	-	4.45

Symbol	Dimensions In Millimeters	
	MIN.	MAX.
E	4.95	5.30
E1	3.50	3.70
e	1.27 BSC.	
H	5.95	6.25
i	-	0.25
L	0.40	0.85
L1	0.27	0.57
L2	0.80	1.30
θ	0°	8°