

N-Channel Enhancement Mode MOSFET

1. Product Information

1.1 Features

- Surface-mounted package
- Advanced trench cell design
- Super Trench
- MSL1

1.2 Applications

- BMS
- High power inverter system
- Drones
- Light electric vehicles

1.3 Quick reference

- $BV \geq 100\text{ V}$
- $R_{DS(ON)} \leq 1.6\text{m}\Omega @ V_{GS} = 10\text{ V}$
- $P_{tot} \leq 300\text{ W}$
- $R_{DS(ON)} \leq 2.5\text{m}\Omega @ V_{GS} = 6\text{ V}$
- $I_D \leq 250\text{ A}$

2. Pin Description

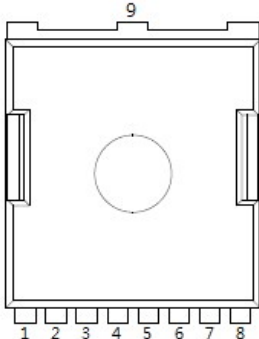
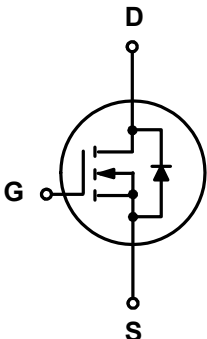
Pin	Description	Simplified Outline	Symbol
1	Gate(G)	 <p>Top View TOLL</p>	
2,3,4,5,6,7,8	Source(S)		
9	Drain(D)		

3. Limiting Values

Symbol	Parameter	Rating	Unit	
V _{DS}	Drain-Source Voltage	100	V	
V _{GS}	Gate-Source Voltage	± 20	V	
I _D ^{Note3}	Drain Current	T _C = 25 °C	250	A
		T _C = 100 °C	206	A
I _{DM} ^{Note2}	Pulsed Source Current	T _C = 25 °C	1000	A
I _S	Diode Forward Current	T _C = 25 °C	250	A
E _{AS}	Single Pulsed Avalanche Energy	L= 1.0mH	2265	A
P _{tot}	Total Power Dissipation	T _C = 25 °C	300	W
R _{θJA} ^{Note1}	Thermal Resistance- Junction to Ambient		49	°C / W
R _{θJC}	Thermal Resistance- Junction to Case		0.5	°C / W
T _{stg}	Storage Temperature		-55~175	°C
T _J	Junction Temperature		175	°C

Note 1 : Surface Mounted on 1 in² pad area, t ≤ 10 sec.

Note 2 : Pulse test; pulse width ≤ 300 μs, duty cycle ≤ 2%.

Note 3 : Limited by bonding wire.

4. Marking Information

Product Name	Marking
UP016N10T	

5. Ordering Code

Product Name	Package	Reel Size	Tape width	Quantity	Note
UP016N10T	TOLL-8L			2000	

6. Electrical Characteristics ($T_A=25^\circ$ Unless Otherwise Noted)

Symbol	Parameter	Conditions	Min	Typ	Max	Unit
Static Characteristics						
BV_{DSS}	Drain-Source Breakdown Voltage	$V_{GS} = 0\text{ V}, I_{DS} = 250\ \mu\text{A}$	100	-	-	V
$V_{GS(th)}$	Gate Threshold Voltage	$V_{DS} = V_{GS}, I_{DS} = -250\ \mu\text{A}$	2	-	4	V
I_{DSS}	Drain Leakage Current	$V_{DS} = 80\text{ V}, V_{GS} = 0\text{ V}$	-	-	1	μA
I_{GSS}	Gate Leakage Current	$V_{DS} = 0\text{ V}, V_{GS} = \pm 20\text{ V}$	-	-	± 100	nA
$R_{DS(ON)Note1}$	On-State Resistance	$V_{GS} = 10\text{ V}, I_{DS} = 50\text{ A}$	-	1.3	1.6	m Ω
		$V_{GS} = 6\text{ V}, I_{DS} = 30\text{ A}$	-	1.9	2.5	
Diode Characteristics						
V_{SD}^{Note1}	Diode Forward Voltage	$I_{SD} = 50\text{ A}, V_{GS} = 0\text{ V}$	-	-	1.3	V
t_{rr}	Reverse Recovery Time	$I_{DS} = 50\text{ A}, V_{GS} = 0\text{ V}$	-	83	-	nS
Q_{rr}	Reverse Recovery Charge	$di_{SD}/dt = 100\text{ A}/\mu\text{s}$	-	142	-	nC
Dynamic Characteristics^{Note2}						
C_{iss}	Input Capacitance	$V_{GS} = 0\text{ V}, V_{DS} = 50\text{ V}$ Frequency = 1 MHz	-	9936	-	pF
C_{oss}	Output Capacitance		-	1708	-	
C_{rss}	Reverse Transfer Capacitance		-	67	-	
$t_d(on)$	Turn-on Delay Time	$V_{DS} = 50\text{ V}, V_{GEN} = 10\text{ V},$ $R_G = 3.9\ \Omega, R_L = 1\ \Omega,$ $I_{DS} = 50\text{ A}$	-	31	-	nS
t_r	Turn-on Rise Time		-	101	-	
$t_d(off)$	Turn-off Delay Time		-	121	-	
t_f	Turn-off Fall Time		-	102	-	
Gate Charge Characteristics^{Note2}						
Q_g	Total Gate Charge	$V_{DS} = 50\text{ V}, V_{GS} = 10\text{ V},$ $I_{DS} = 50\text{ A}$	-	190	-	nC
Q_{gs}	Gate-Source Charge		-	51	-	
Q_{gd}	Gate-Drain Charge		-	56	-	

Note 1: Pulse test; pulse width $\leq 300\ \mu\text{s}$, duty cycle $\leq 2\%$.

Note 2: Guaranteed by design, not subject to production testing.

7. Typical Characteristics

Power Capability

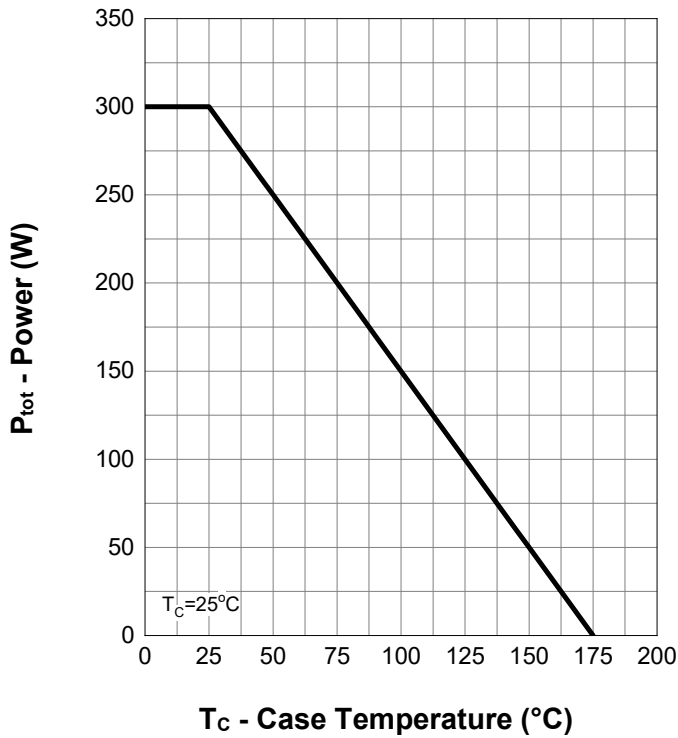

Current Capability

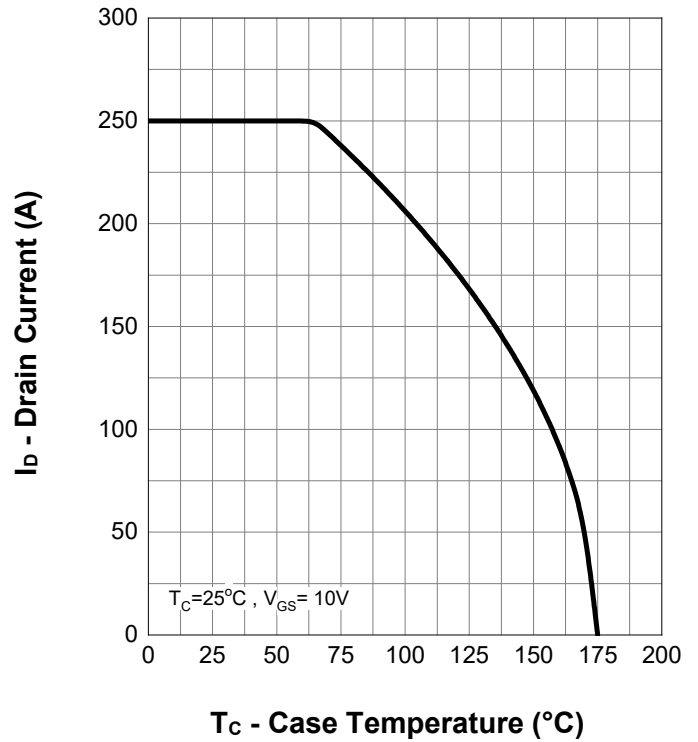

Safe Operating Area

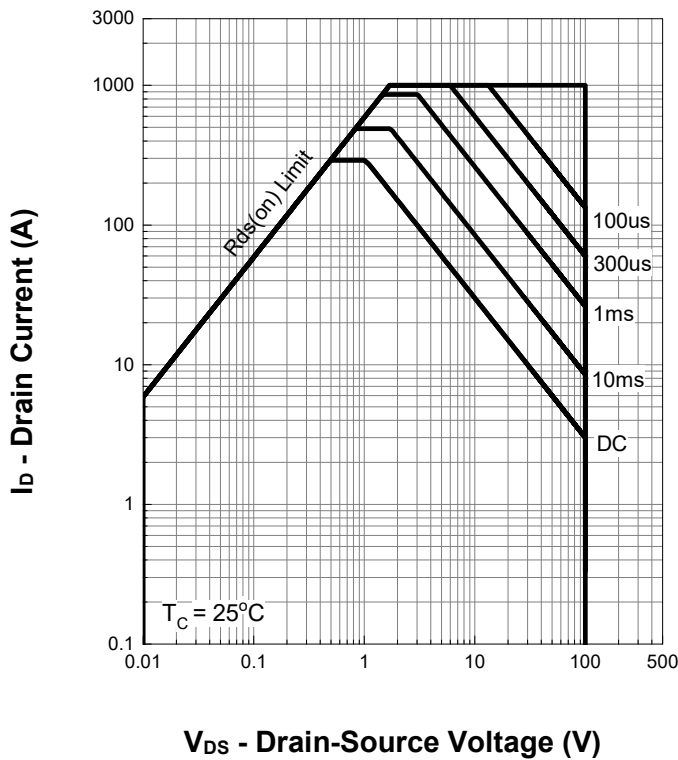

Transient Thermal Impedance

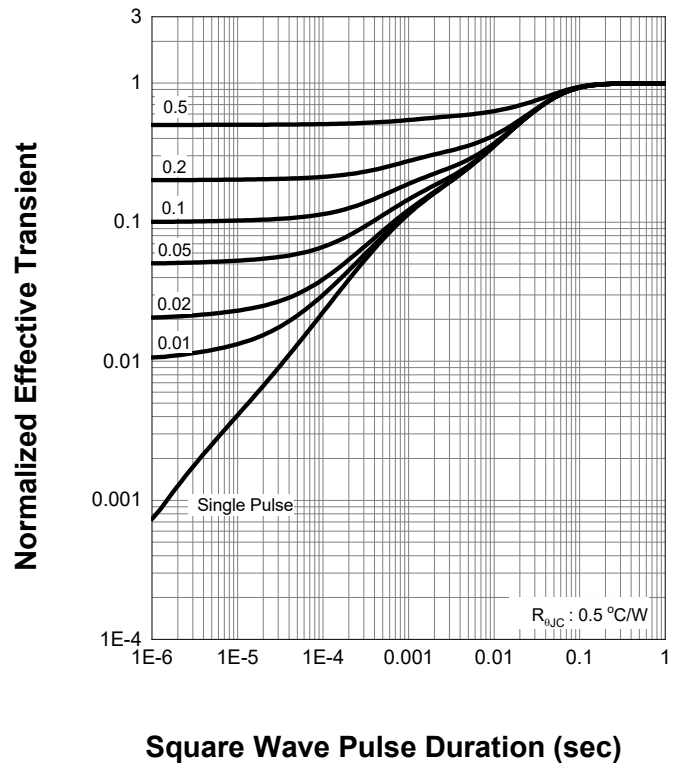

7. Typical Characteristics (cont.)

Output Characteristics

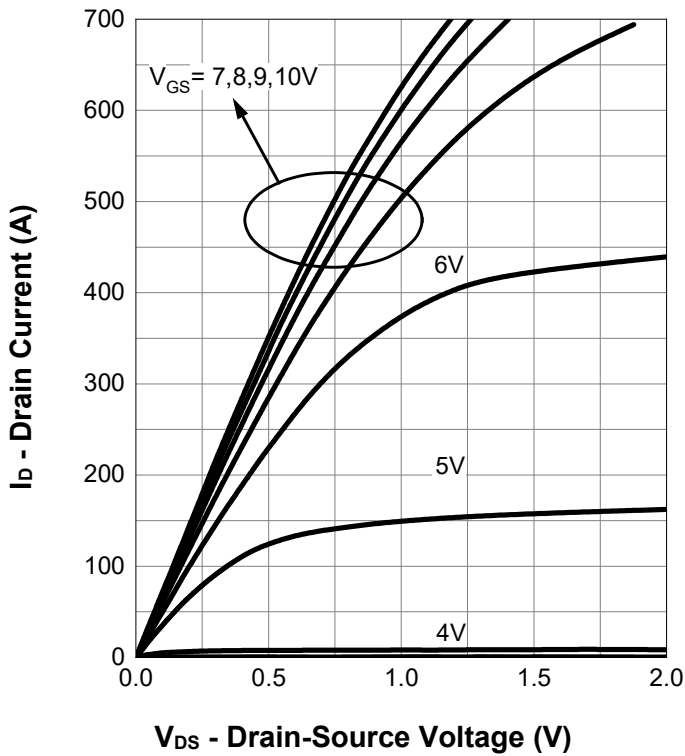

On Resistance

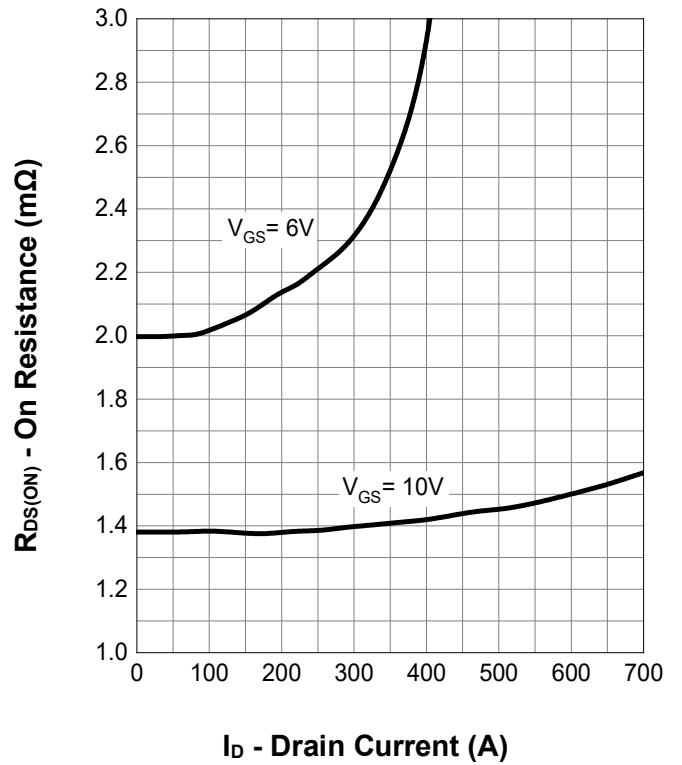

Transfer Characteristics

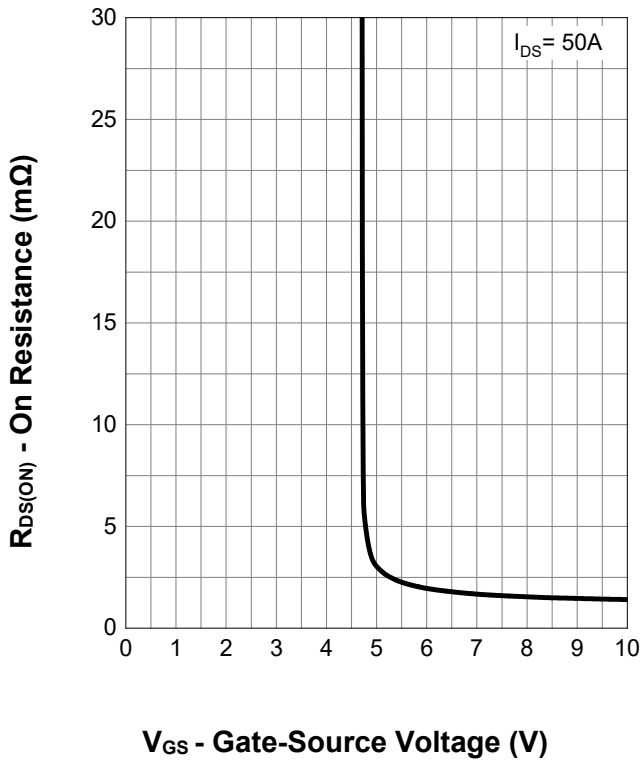

Normalized Threshold Voltage

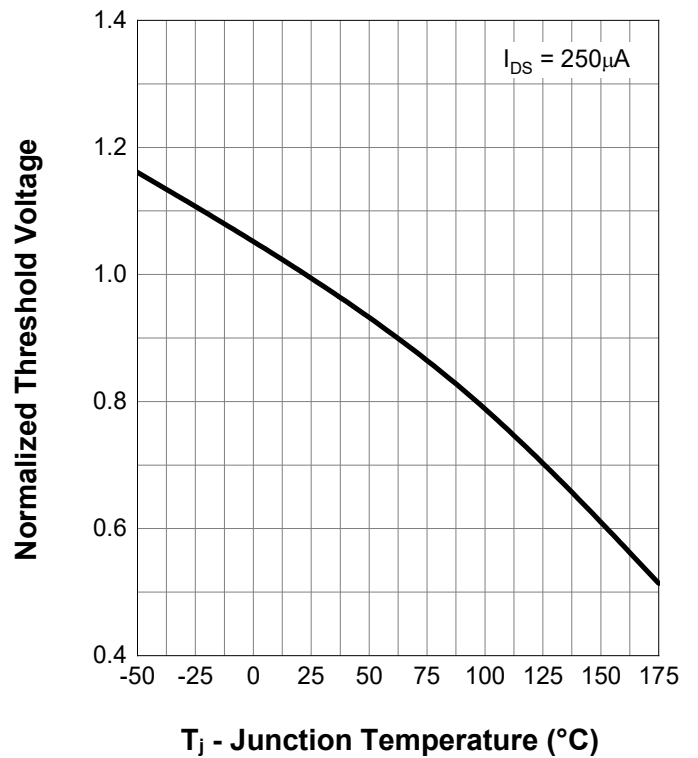

7. Typical Characteristics (cont.)

Normalized On Resistance

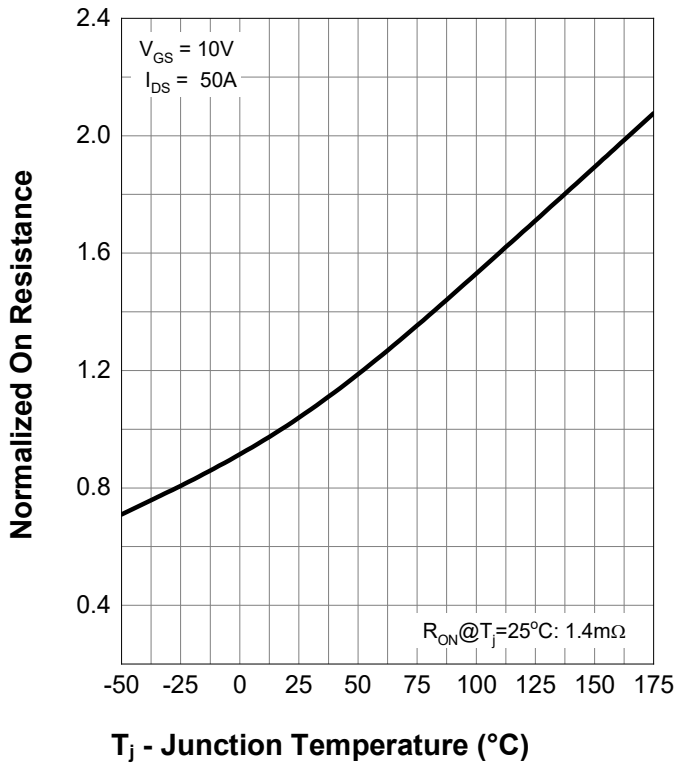

Diode Forward Current

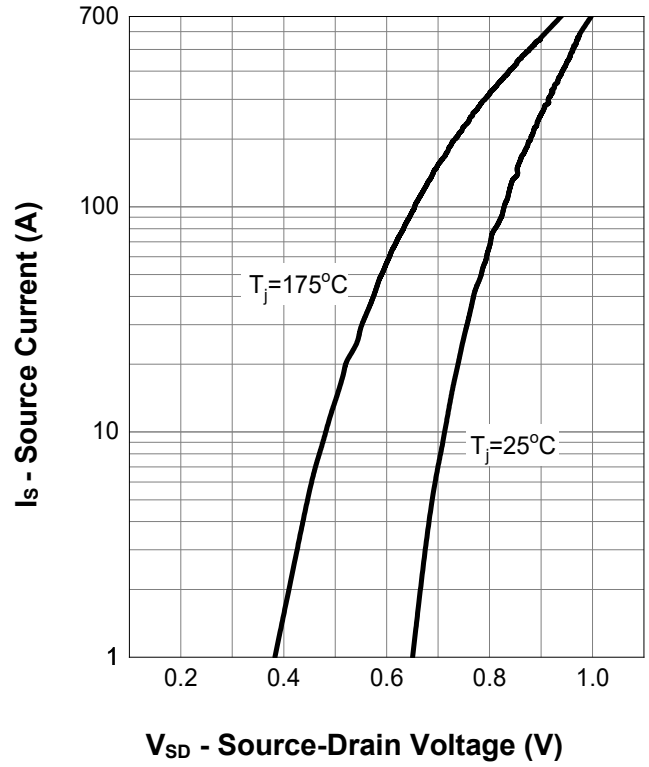

Capacitance

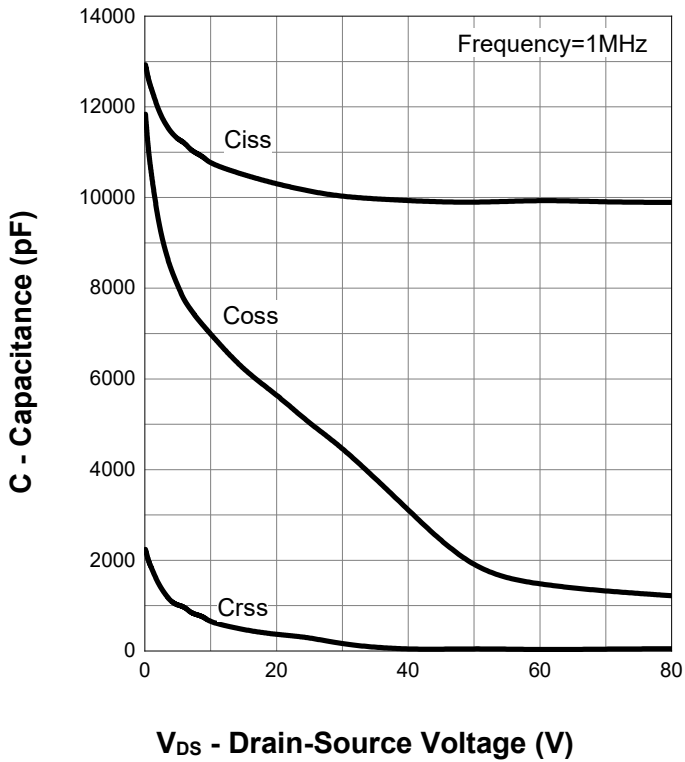

Gate Charge

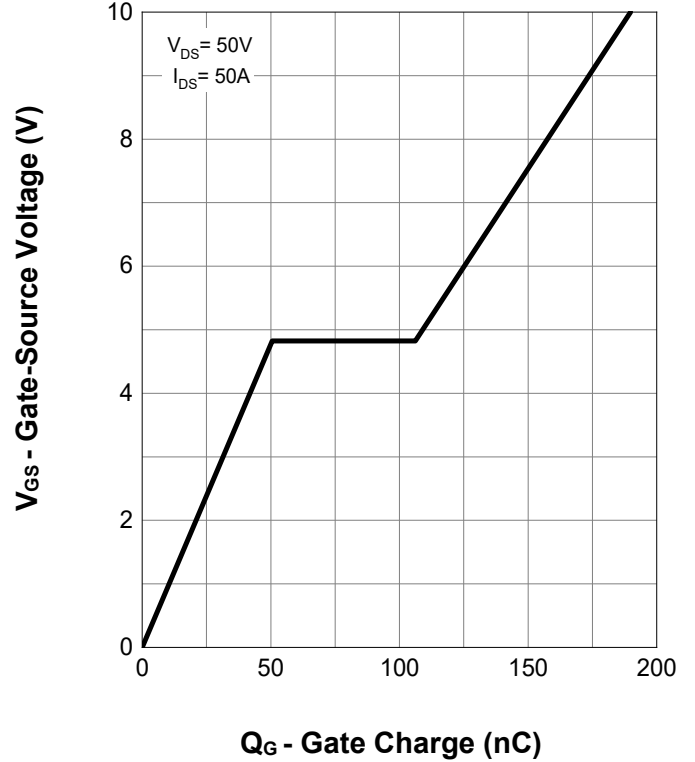

8. Package Dimensions

TOLL-8L Package

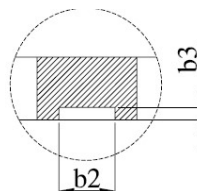
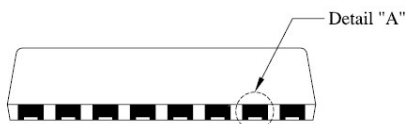
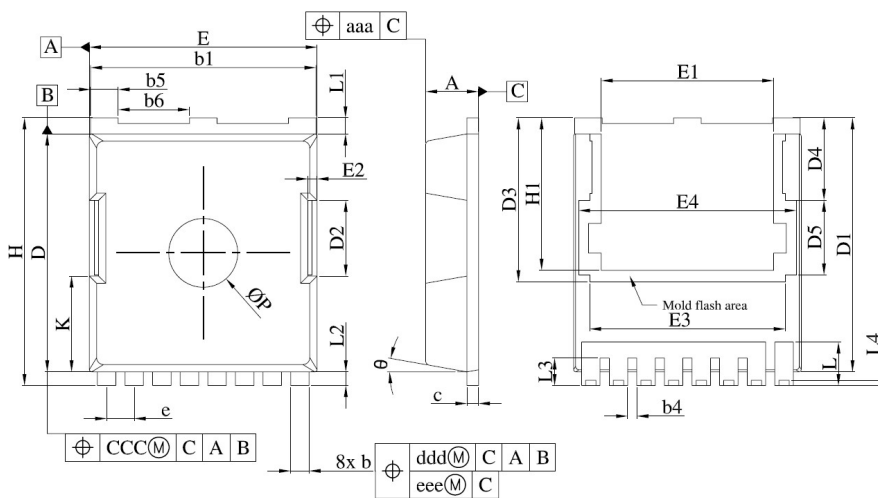

Symbol	Dimensions In Millimeters		
	MIN.	NOM.	MAX.
A	2.20	2.30	2.40
b	0.70	0.80	0.90
b1	9.70	9.80	9.90
b2	0.36	0.45	0.55
b3	0.05	0.10	/
b4	0.30	0.40	0.50
b5	1.10	1.20	1.30
b6	3.00	3.10	3.20
c	0.40	0.50	0.60
D	10.28	10.38	10.55
D1	10.98	11.08	11.18
D2	3.20	3.30	3.40
D3	7.15		
D4	3.59		
D5	3.26		
e	1.10	1.20	1.30
E	9.80	9.90	10.00
E1	7.40	7.50	7.60
E2	0.30	0.40	0.50
E3	8.50		
E4	9.46		
H	11.50	11.68	11.85
H1	6.55	6.65	6.75
K	4.08	4.18	4.28
L	1.60	1.90	2.10
L1	0.50	0.70	0.90
L2	0.50	0.60	0.70
L3	1.00	1.20	1.30
L4	0.13	0.23	0.33
p	2.85	3.00	3.15
θ	10°REF		
aaa	0.20		
ccc	0.20		
ddd	0.25		
eee	0.20		